



Micro Data Center

Technical Data Manual



Contents

1. INTRODUCTION.....	3
1.1 Product Introduction.....	3
2.1 Major Components Introduction.....	5
3.1 Environmental Requirements.....	6
2. TECHNICAL DATA.....	7
3. INSTALLATION DATA.....	9

1. INTRODUCTION

1.1.. Product Introduction

A Micro data center is a standalone rack-level system containing all the components of a 'traditional' data center including precision cooling, UPS power supply, power backup, cabinets, security, and monitoring systems. Their size, versatility and plug & play features make them an ideal solution for use in remote locations, branch offices, or even for temporary use in high risk zones.

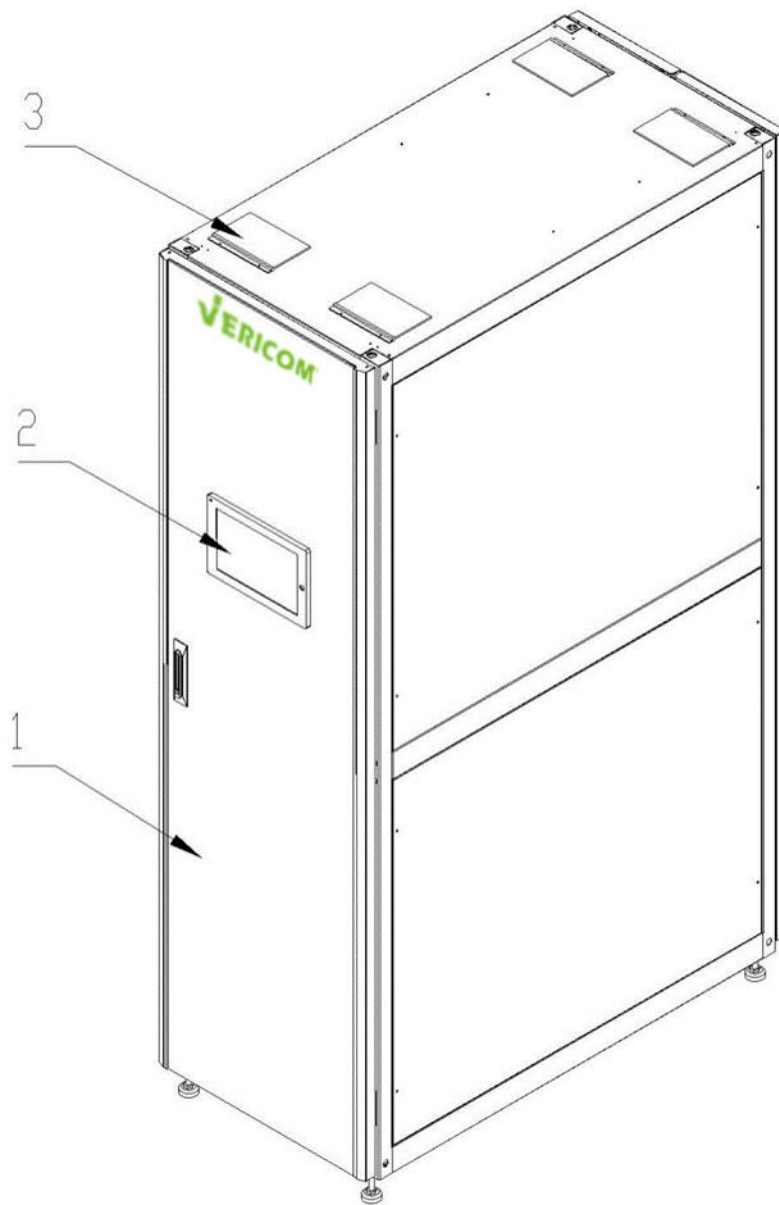

Figure 1-1 Exterior Layout

1	Glass door	2	Monitoring host	3	Cable entry holes
---	------------	---	-----------------	---	-------------------

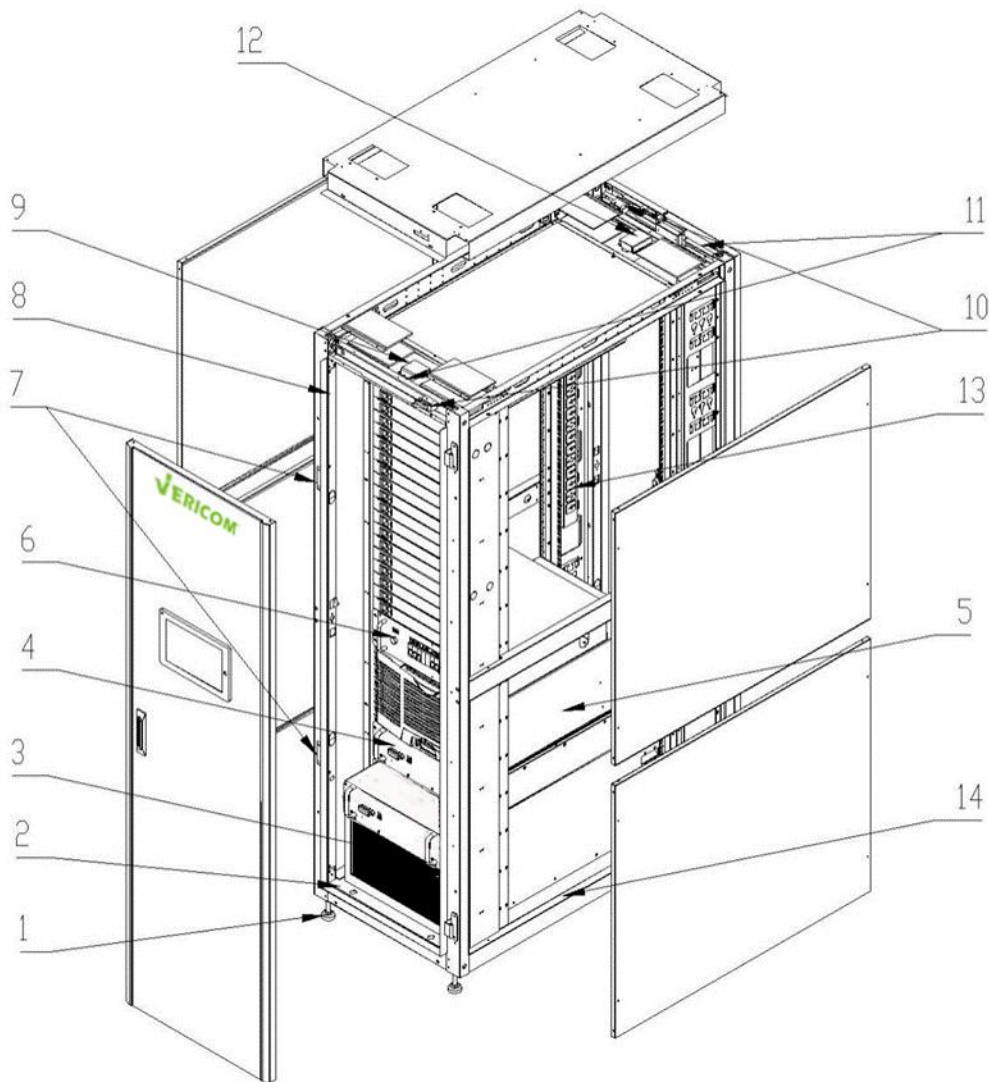

Figure 1-2 Internal Layout

1	Leveling feet	2	Castors	3	Air Conditioner
4	Battery Pack	5	UPS	6	Power distribution module
7	Mechanical lock	8	Backlight	9	Temperature and Humidity Sensor
10	Switch	11	Lighting	12	Smoke Sensor
13	PDU	14	Water Leakage Rope		

2.1.. Major Components Introduction

- **UPS**—The UPS has two main functions, one is to optimize the input power supply to provide clean power to the critical load equipment, the second is the use of battery backup for the critical load equipment after the main power supply fails or drops to an unacceptable level.
- **Battery**—When the main power supply is normal, power is stored in battery bank. In the event of the electricity failure, the batteries are discharged through the UPS to critical load equipment.
- **Air conditioner**—Provides stable temperature, humidity and clean air for critical load equipment.
- **Power distribution module**—Power distribution and monitoring for critical load and infrastructure equipment.
- **Monitoring system**—The monitoring host is the information center of entire device and the hub of human-computer interaction. It monitors, controls, and provides alarms for the entire system, including the UPS, air conditioner, power distribution module, temperature and humidity sensors, and other intelligent equipment. It also monitors and provides alarms for the door switch status, leak detection status, and other dry contacts. All information can be monitored remotely by network (for details refer to the monitoring system chapter).
- **Blank panel**—Installed in unused rack spaces to maintain hot and cold air isolation and improve the operating efficiency of the air conditioning system.
- **Temperature and humidity sensor**—Detects the cold aisle temperature and humidity of the cabinet.
- **Light**—When the cabinet door is opened, the lights are automatically lit to facilitate operation of the internal equipment.
- **Door switch**—Detects the door status (open or closed) and provides the corresponding signal to the monitoring host; also controls the lights.
- **Smoke sensor**—Detects smoke inside the cabinet; if smoke is detected, an alarm is sounded and an alarm signal is sent to the monitoring host.
- **Wiring channel**—Arrange the rear wiring of the monitoring host, improve the maintenance convenience and appearance experience.
- **Electromagnet**—The core device of automatic doors, the electromagnet automatically opens the doors if a high temperature is detected.
- **Castors**—During initial installation, allows the device to roll over smooth, hard surfaces into the final position.
- **Leveling feet**—After the device is placed into the final position, leveling feet are used to level the device on uneven surfaces. If necessary, adjust the four leveling feet to raise the device to an appropriate level so that the copper pipe, cable and drain pipe can be routed underneath.

3.1.. Environmental Requirements

Operating Environment

Table 1-1 Product Operating Environment

Item	Indoor	Outdoor
Temperature	18°C~40°C	Air cooled: -20°C~+55°C
Humidity	20% ~80%	—
Altitude	<1000m (if >1000m, derating capacity of air conditioner and UPS will be 6% per kilometer)	
Power	Voltage 230V/380V±10% Frequency 50Hz±2Hz	

Storage Environment

Table 1-2 Product Storage Environment

Item	Requirements
Environment	Clean (no dust), good ventilation
Temperature	-40°C~+60°C
Humidity	5%RH~95%RH without condensation
Duration	less than 6 months, (If more than 6 months, please contact Vericom technical support)

2. TECHNICAL DATA

Table 2-1 Vericom Micro Data Center Technical Specifications

Model	VRMDC3000-R1G-U3KVA1-C4KW1-M-PD2
Available Space	24U
Width per Cabinet	600
Depth per Cabinet	1200
Height per Cabinet	2000
Cabinet System	
Load-bearing	1500kg
Aisle Containment	Hot and cold aisle containment
Front Door	Single glass door
Rear Door	Double iron door
Power Supply and Distribution System	
Power Input	220V/50Hz/1Ph
Power Output	220V/50Hz/1Ph
UPS (kVA)	3
UPS Qty	1
UPS Configuration	N
UPS Output PF	0.9
UPS Efficiency	95%
UPS Installation Type	Rack-mount
Battery Qty	(12V/9AH/8pcs)*2

Long Time Delay Battery	Optional
Lightning/Surge Protection	C-Class
Manual Maintenance Bypass	Support
PDU Type	Basic (16A)
PDU Qty	2
PDU interface	(7*BS1363+3*C13)
Cooling System	
Cooling Capacity	1*4.2
Configuration	N, Support teamwork control
Sensible Heat Ratio	95%
Maximum Airflow- -m3/h	800
Air conditioning Qty	1
Cooling Type	DX cooling
Installation Type	Rack-mount
Monitoring System	
Monitoring Function	Touch screen display
	Remote access
	Temperature and Humidity Detection
	UPS monitoring
	Power distribution module monitoring
	Air conditioning monitoring
	Smoke detection
	Leakage detection
	Door status detection

3. INSTALLATION DATA

Table 3-1 Micro Data Center Product Dimension

Model	Width-mm	Depth-mm	Height-mm
VRMDC3000-R1G-U3KVA1-C4KW1-M-PD2	600	1200	2050

Table 3-2 Dimension of Outdoor Unit

Model	Width-mm	Depth-mm	Height-mm
D06WP13VSG-04-S	830	325	540

Table 3-3 Dimension and Gross Weight of Outdoor Unit After Packing

Model	Dimension after packing(mm)W×D×H	Gross Weight(kg)
D06WP13VSG-04-S	900×400×600	32

[Remark: L-Length, W-Width, H-Height]

Table 3-4 Dimension and Gross Weight of Indoor Unit After Packing

Model	Dimension after packing(mm)W×D×H	Synthesize cabinet/subsidiary cabinet Gross Weight(kg)
VRMDC3000	N*W680XD1280XH2080(With pallet W700XD1280XH2210)	380/140

[Remark: N-Quantity of cabinets, W-Width, D-Depth, H-Height, weight is for reference only, and the weight will vary according to the configuration]